



The sensors SEMIFLOW CO.65/xxxPI V2.0 – designed as clamp-on-sensors with flexible inlay – detect the flow rate of liquids in rigid tubes of different diameters within a few milliseconds. Industrial applications in the **semiconductor industry** are typical: use in wafer cleaning equipment, lithography equipment, mixing equipment, chemical supply systems or slurry lines. The sensors have no contact to the fluid and are suitable for all applications with strict hygienic requirements, e.g. **biotechnology, pharmaceutical industries or chemical industry**. Due to the switching output the sensors support industrial dosing applications. The RS-485 interface (SONOTEC protocol; Modbus via software settings) allows bus operation. The SEMIFLOW CO.65/xxxPI V2.0 sensors with complete built-in electronics can be installed in machines or apparatuses.

General sensor specification

Specification SEMIFLOW	Measuring channel Width Width with Inlay (see also technical drawings)	Standard Tubing OD	Dimensions (L × W × H)	Weight
CO.65/080PI V2.0	8 mm 5 mm	1/4 "	44 × 44 × 34 mm	90 g
CO.65/120PI V2.0	12 mm 8.5 mm	3/8 "	44 × 44 × 38 mm	100 g
CO.65/160PI V2.0	16 mm 12 mm	1/2 "	44 × 56 × 41 mm	130 g
CO.65/190PI V2.0	19.5 mm 17.8 mm	3/4 "	50 × 76 × 54 mm	260 g
CO.65/260PI V2.0	26 mm 23.4 mm	1 "	50 × 76 × 60 mm	280 g
CO.65/340PI V2.0	34 mm 32 mm	1.32 "	58 × 84 × 62 mm	340 g
CO.65/500PI V2.0	50 mm 45.4 mm	48.5 mm	70 × 116 × 75 mm	840 g
CO.65/630PI V2.0	63 mm 57.4 mm	61 mm	80 × 130 × 90 mm	950 g

Tubing properties

Material: Homogeneous rigid plastic tubing (e.g. PFA, PTFE, PA, PU)
To realize an acoustic coupling of the sensor and the rigid tubing, the measuring channel has a built-in flexible inlay.

NOTE! Sensors are factory calibrated with standard tubing, unless requested differently. Customized calibration is documented in the sensor calibration report.

Accuracy

Specification SEMIFLOW	Accuracy for water with standard flow rate and standard tubing, adjusted at 23 °C ± 2 K and 1 bar		Typical max. flow
CO.65/080PI V2.0	< 800 ml/min: ± 16 ml/min	> 800 ml/min: ± 2 % ⁽¹⁾	6 000 ml/min ⁽²⁾
CO.65/120PI V2.0	< 1 200 ml/min: ± 24 ml/min	> 1 200 ml/min: ± 2 % ⁽¹⁾	20 000 ml/min ⁽²⁾
CO.65/160PI V2.0	< 1 600 ml/min: ± 32 ml/min	> 1 600 ml/min: ± 2 % ⁽¹⁾	40 000 ml/min ⁽²⁾
CO.65/190PI V2.0	< 1 800 ml/min: ± 36 ml/min	> 1 800 ml/min: ± 2 % ⁽¹⁾	60 000 ml/min ⁽²⁾
CO.65/260PI V2.0	< 4 000 ml/min: ± 80 ml/min	> 4 000 ml/min: ± 2 % ⁽¹⁾	80 000 ml/min ⁽²⁾
CO.65/340PI V2.0	< 14 000 ml/min: ± 280 ml/min	> 14 000 ml/min: ± 2 % ⁽¹⁾	150 000 ml/min ⁽²⁾
CO.65/500PI V2.0	< 16 000 ml/min: ± 480 ml/min	> 16 000 ml/min: ± 3 % ⁽¹⁾	250 000 ml/min ⁽²⁾
CO.65/630PI V2.0	< 18 000 ml/min: ± 540 ml/min	> 18 000 ml/min: ± 3 % ⁽¹⁾	290 000 ml/min ⁽²⁾

Customized calibration is documented in the sensor calibration report.

Technical data

SEMIFLOW – Flow sensor for liquids								
Measuring method	Ultrasound, two sections of measurements, dry coupling, built-in flexible inlay							
Calibration	Sensors are factory calibrated for water at 23 °C ± 2 K, tube end depressurized; other calibration on request							
Mounting	<table border="0"> <tr> <td rowspan="3">Fixed installation with screws: 4 fixing holes</td> <td>CO.65/080PI V2.0 ... CO.65/160PI V2.0</td> <td>M4, depth 8 mm</td> </tr> <tr> <td>CO.65/190PI V2.0 ... CO.65/340PI V2.0</td> <td>M6, depth 10 mm</td> </tr> <tr> <td>CO.65/500PI V2.0 ... CO.65/630PI V2.0</td> <td>M10, depth 12 mm</td> </tr> </table>	Fixed installation with screws: 4 fixing holes	CO.65/080PI V2.0 ... CO.65/160PI V2.0	M4, depth 8 mm	CO.65/190PI V2.0 ... CO.65/340PI V2.0	M6, depth 10 mm	CO.65/500PI V2.0 ... CO.65/630PI V2.0	M10, depth 12 mm
Fixed installation with screws: 4 fixing holes	CO.65/080PI V2.0 ... CO.65/160PI V2.0		M4, depth 8 mm					
	CO.65/190PI V2.0 ... CO.65/340PI V2.0		M6, depth 10 mm					
	CO.65/500PI V2.0 ... CO.65/630PI V2.0	M10, depth 12 mm						
Media	Water or other acoustically transparent liquids							
Sensor materials	Channel: PMMA black Inlay: silicone rubber (others on request) Housing: PVC-C grey Potting: PU Cover screws: PA natural Connector: PA black Pins: brass							
Operating voltage	12 ... 30 VDC, maximum ripple 10 %, protection against reverse-polarity (external fuse, if required: min. 200 mA)							
Current consumption	Maximum 50 mA (with open current, frequency and switching output depending on supply voltage)							
Electrical connection	8 pin connector (Binder 720 male)							
Shielding	⚠ Required: Shield of cable has to be connected on side of machine							

⁽¹⁾ [Percent] of measurement reading. | ⁽²⁾ Unless requested differently. Limited by tubing capacity only.

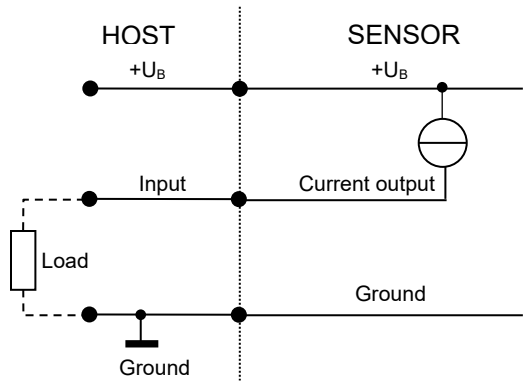
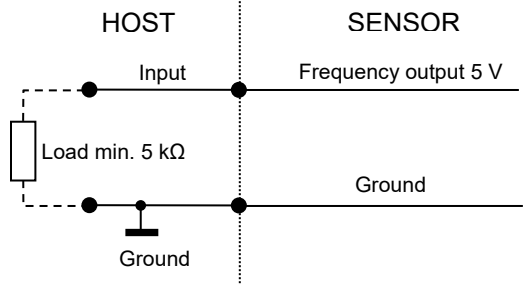
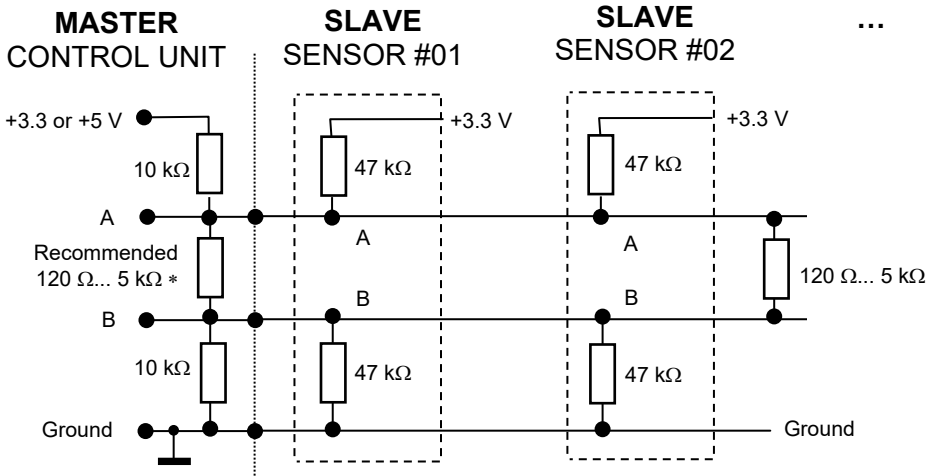
<p>Interfaces</p>	<ul style="list-style-type: none"> • Current output for flow rate: 0/4 ... 20 mA • Frequency output for flow rate: 0 ... 20 kHz, 5 V digital • RS-485 interface: bus-capable (SONOTEC protocol, optional Modbus) • Switching output: configurable as PNP / NPN / Push-Pull, 0 ... 30 V • Digital input
<p>Current output for flow rate</p>	<p>⚠ NOTE: Load to GND. The max. load depends on the operating voltage: 12 V → 250 Ω, 15 V → 500 Ω, 24 V → 1 kΩ, 30 V → 1.2 kΩ</p> 
<p>Frequency output for flow rate</p>	
<p>RS-485 interface</p>	<p>SONOTEC protocol: Half-duplex operation / 115.200 baud / 8 data bit / no parity / 1 stop bit / no handshaking (Modbus via software settings)</p> <p>⚠ NOTE: Description of serial protocol upon request.</p> <p>Recommended electrical connection of the RS-485 interface.</p> <p>⚠ CAUTION! If the interface is not used, the pins A and B shall remain open.</p>  <p>* According to bus standard: depending on number of sensors and cable length</p>

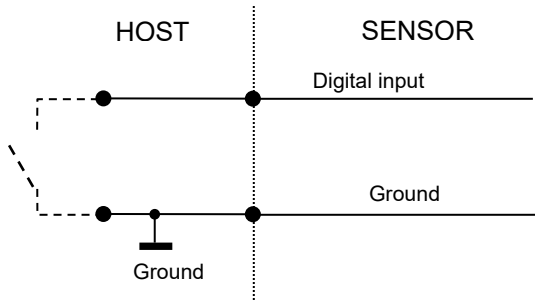
RS-485 bus operation	<p>The sensor supports bus operation with max. 12 devices (SONOTEC protocol). The default address is #01.</p> <p>⚠ NOTE: The address can be changed with the help of the SEMIFLOW Monitor. Permitted are addresses from #01 ... #12. → Menu: Identification RS-485 address</p>
Switching output	<p>PNP / NPN / Push-Pull, 0 ... 30 V, maximum 100 mA, configurable for applications such as</p> <ul style="list-style-type: none"> • Adapting batch process (dosing) • Threshold switch of flow • Slow pulses of volume (max.. 20 Hz)
Digital input	<p>Freely configurable. For applications such as:</p> <ul style="list-style-type: none"> • Zero point calibration of flow • Start dosing processes <p>Voltage resistant up to 30 V</p> 
Media temperature (depending on ambient temperature)	<p>Sensors CO.65/080PI V2.0 ... CO.65/340PI V2.0</p> <p>0 ... 90 °C @ 0 ... 25 °C ambient temperature</p> <p>0 ... 60 °C @ 0 ... 60 °C ambient temperature</p> <p>Sensors CO.65/500PI V2.0 CO.65/630PI V2.0</p> <p>0 ... 60 °C</p>
Storage temperature (all sensors)	-20 ... +70 °C
Degree of protection	IP65 (in mated condition)
Directives and standards	<ul style="list-style-type: none"> • EMC directive 2014/30/EU • RoHS: 2011/65/EU, exception: III 7cl/ IV 15, RoHS (EU) 2015/863 • Acoustic emission: IEC 61157
Maintenance	Maintenance-free

<p>Scope of supply</p>	<p>SEMIFLOW according to specification (including cover and screws)</p>
<p>Optional accessories</p>	<p>C³ Software for testing parameter settings, to adjust sensors for a specific application and for recording measurements. The software package contains</p> <ul style="list-style-type: none"> • USB Data Converter, type 013 for the connection to a computer • USB cable, type A-B, length 2 m • 8-pole M12 connecting cable, length 2 m • Switching power supply (12 VDC) • USB flash drive with C³ Software and driver for Windows <hr/> <p>SONOFLOW RD.10 Remote Display including connecting cable for</p> <ul style="list-style-type: none"> • Monitoring sensor performance (display e.g. current flow rate, volume or measuring state) • Zero calibration • Manual volume reset <hr/> <ul style="list-style-type: none"> • Sensor cable SEMIFLOW, 8 pole (Binder 720) 4 wire, 10 m • Sensor cable SEMIFLOW, 8 pole (Binder 720) 8 wire, 10 m • Calibration protocol

Electrical connection

8 pin connector to 4 pole cable:

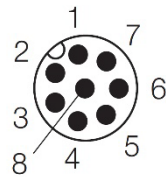

Male connector
(at the sensor)

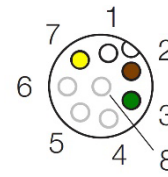

Female connector
(at the cable)

Connecting cable	Pin	Connection	Color*
Assignment	1	Ground	White
	2	Operating voltage +12 ... 30 VDC	Brown
	3	Current output (0/4 ... 20 mA)	Green
	4	RS-485 B	
	5	RS-485 A	
	6	Frequency output 0 ... 20 kHz	
	7	Switching output: PNP / NPN / Push-Pull	Yellow
	8	Digital input	
	Shield	If available, should be connected on side of machine	

8 pin connector to 8 pole cable:

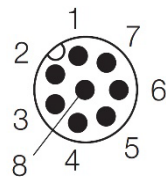

Male connector
(at the sensor)

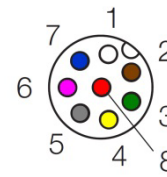

Female connector
(at the cable)



Connecting cable	Pin	Connection	Color*
Assignment	1	Ground	White
	2	Operating voltage +12 ... 30 VDC	Brown
	3	Current output (0/4 ... 20 mA)	Green
	4	RS-485 B	Yellow
	5	RS-485 A	Grey
	6	Frequency output 0 ... 20 kHz	Pink
	7	Switching output: PNP / NPN / Push-Pull	Blue
	8	Digital input	Red
	Shield	If available, should be connected on side of machine	

* of specified SONOTEC cable

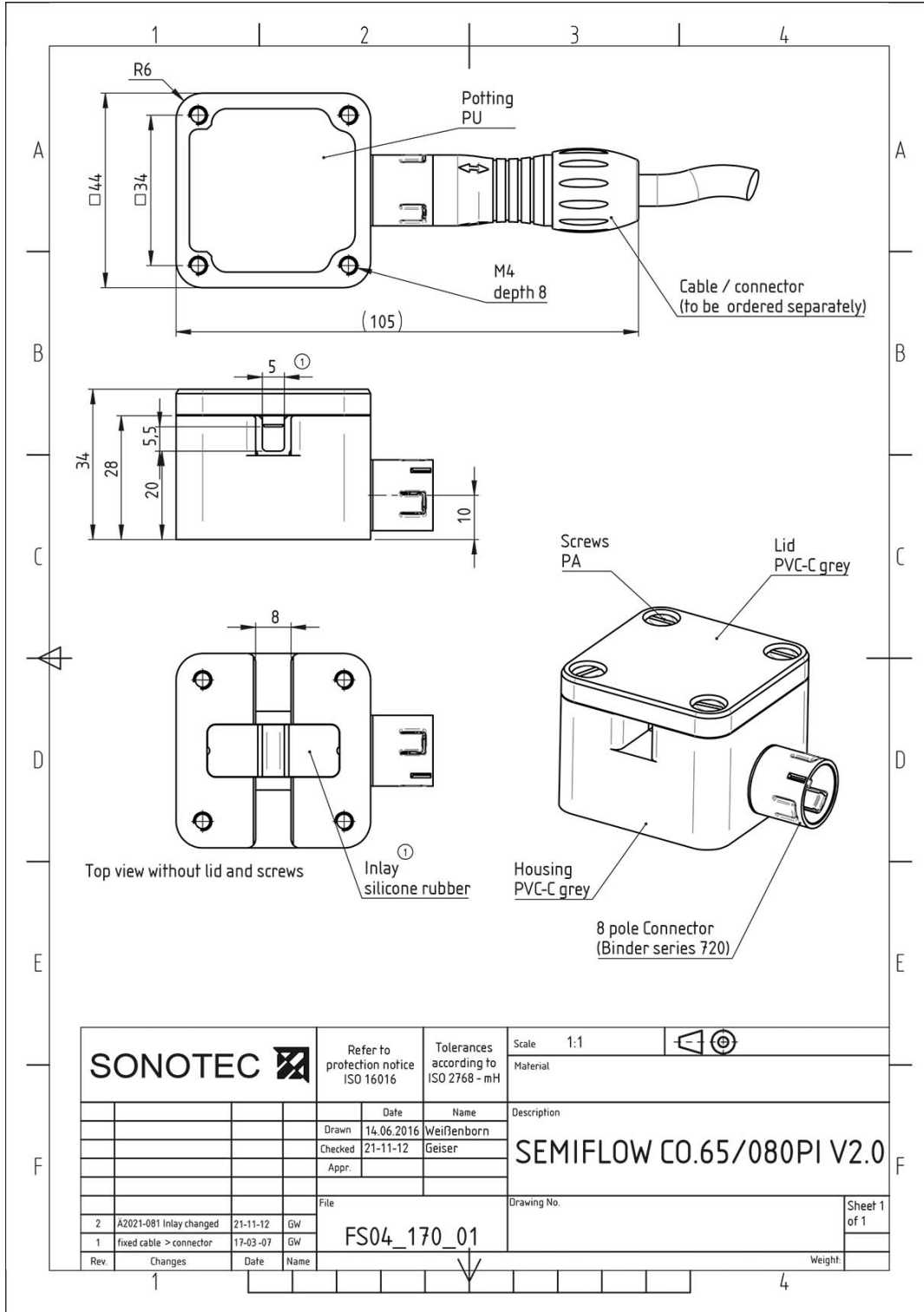

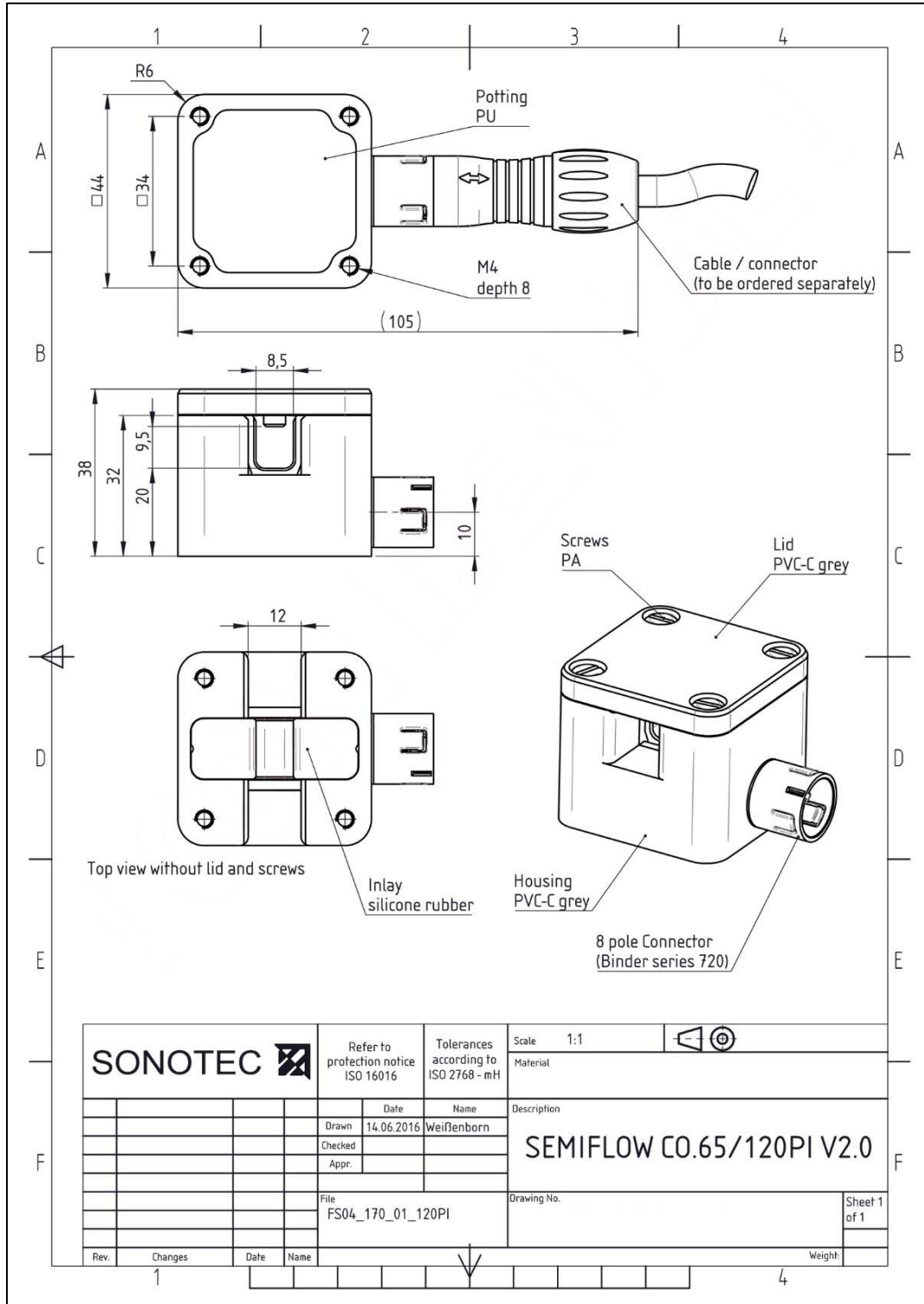
Technical drawings



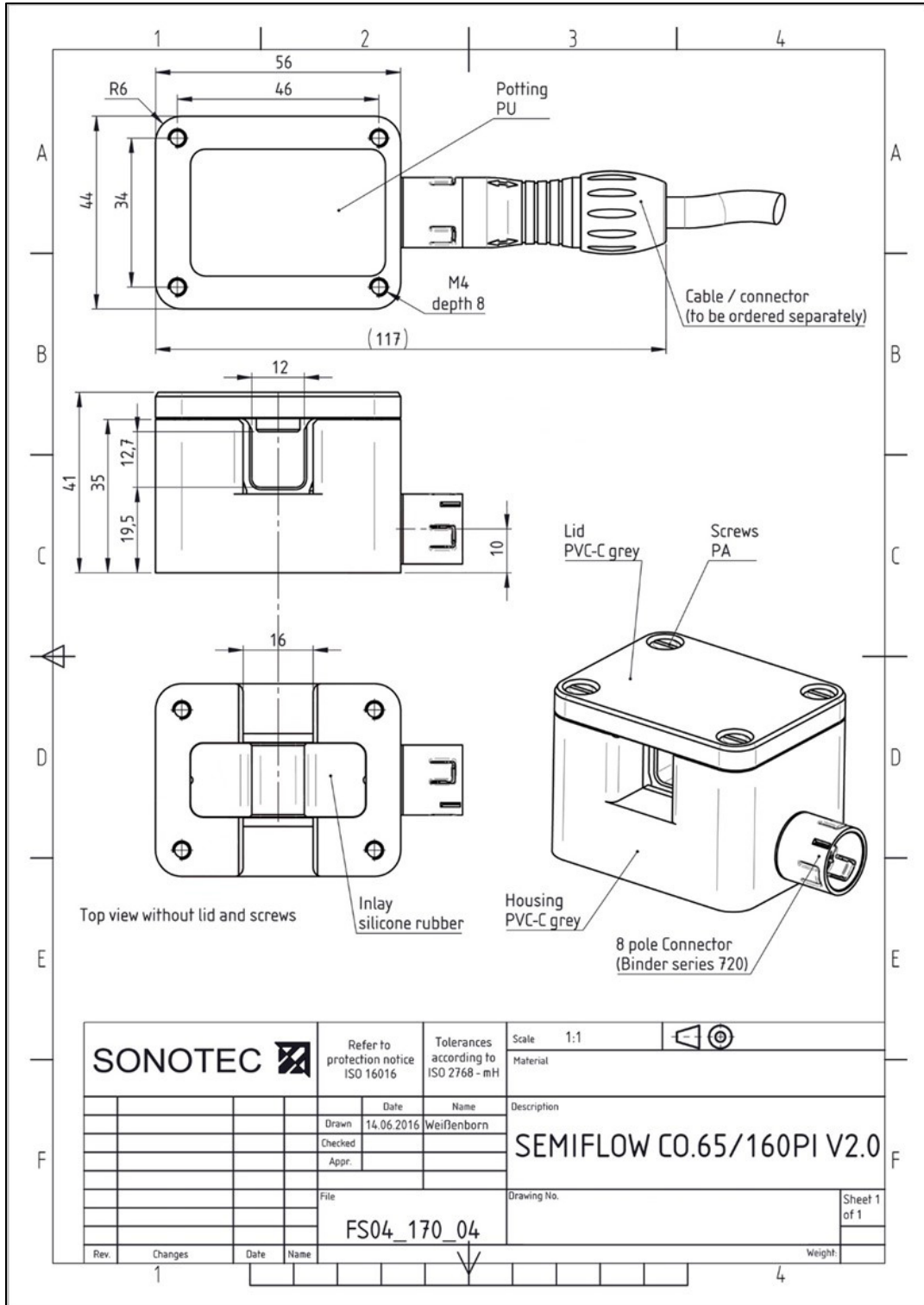

SONOTEC 		Refer to protection notice ISO 16016	Tolerances according to ISO 2768 - mH	Scale 1:1	
		Drawn 14.06.2016	Name Weißenborn	Description	
		Checked		SEMIFLOW CO.65/120PI V2.0	
		Appr.			
		File FS04_170_01_120PI	Drawing No.	Sheet 1 of 1	
Rev.	Changes	Date	Name	Weight	
1					



SONOTEC 		Refer to protection notice ISO 16016	Tolerances according to ISO 2768 - mH	Scale 1:1	
		Material	Description		
		Drawn 14.06.2016	Name Weißenborn	SEMIFLOW CO.65/160PI V2.0	
		Checked	Drawing No.		
		Appr.	File		Sheet 1 of 1
		FS04_170_04			Weight
Rev.	Changes	Date	Name		
1					

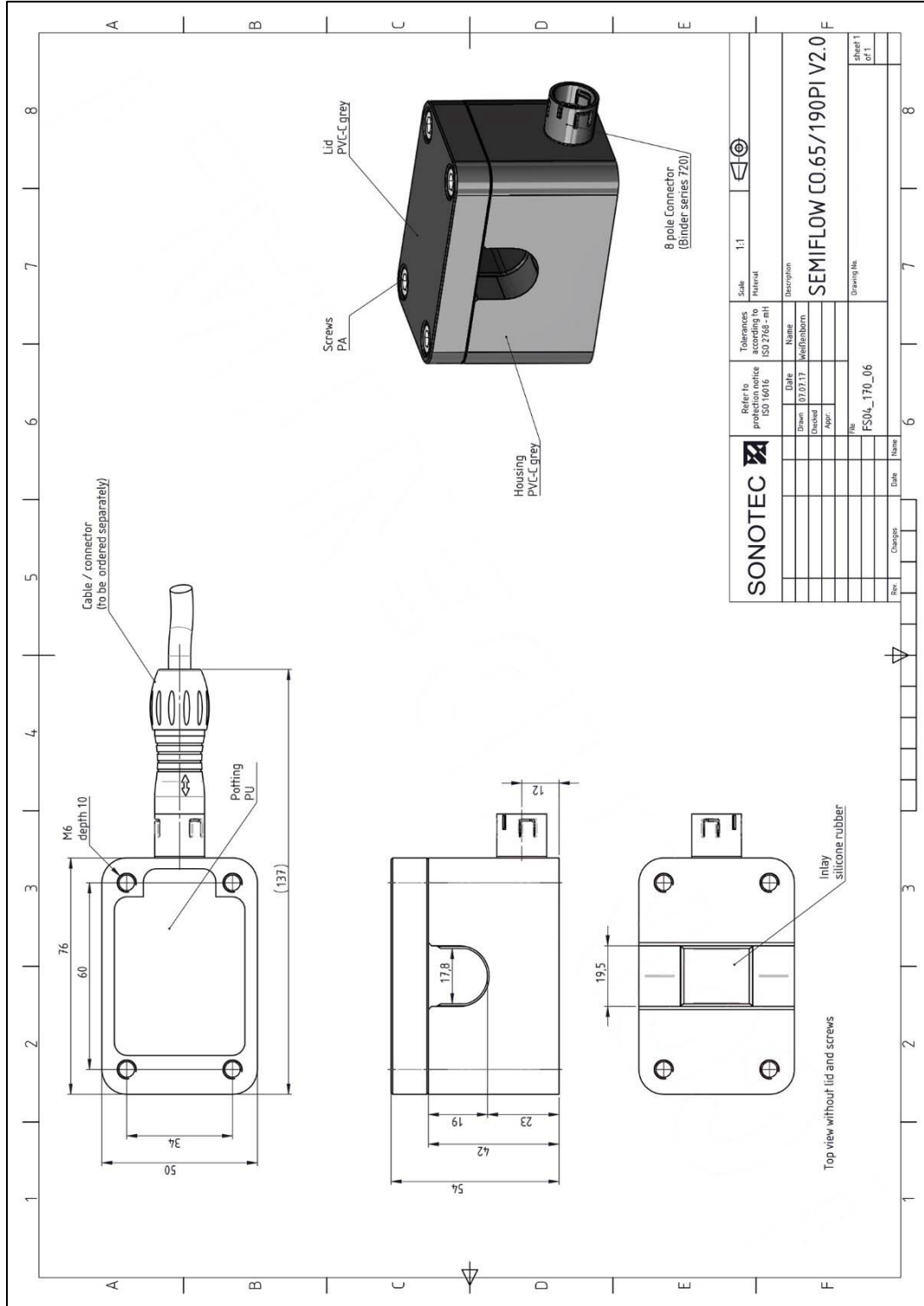

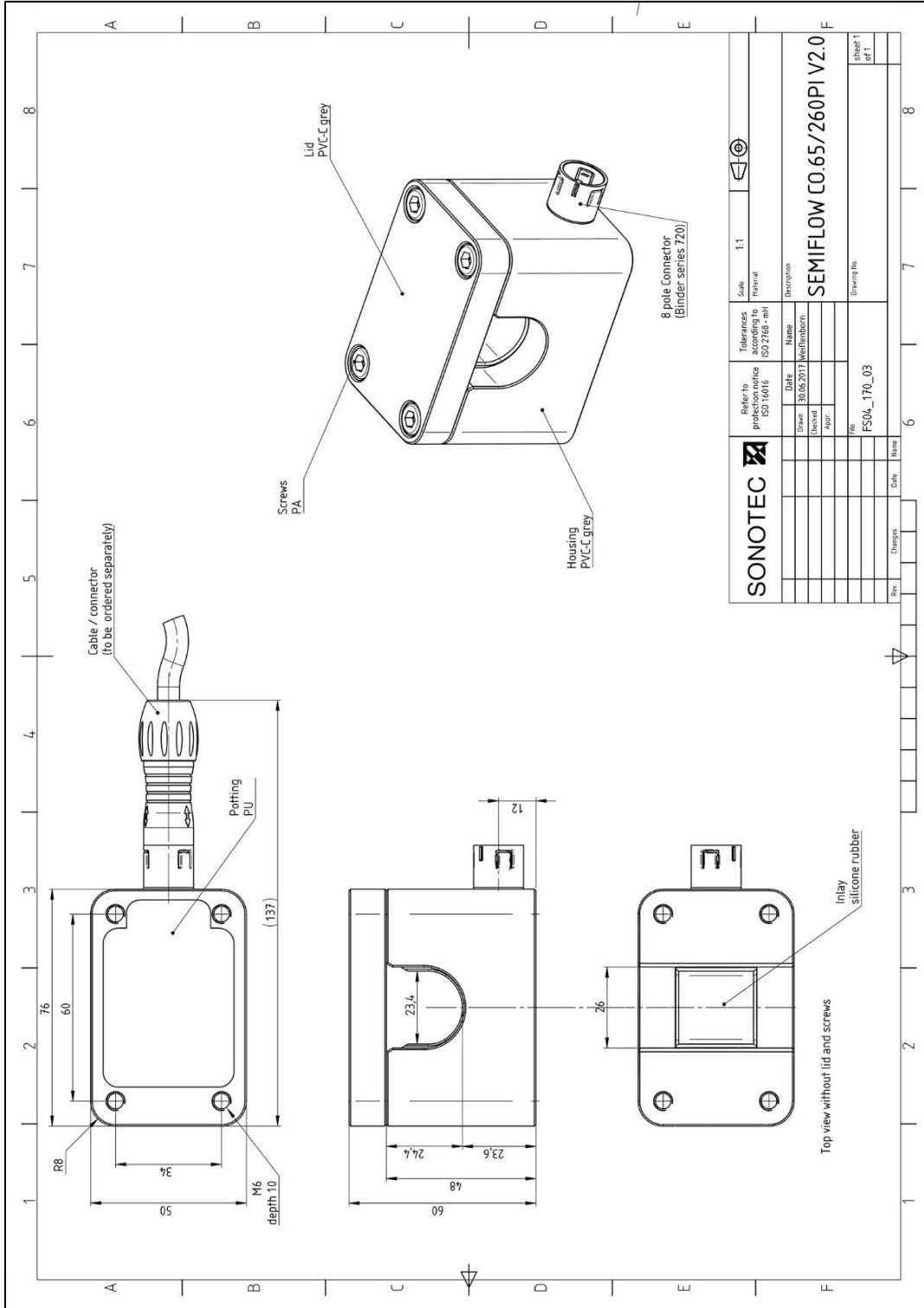

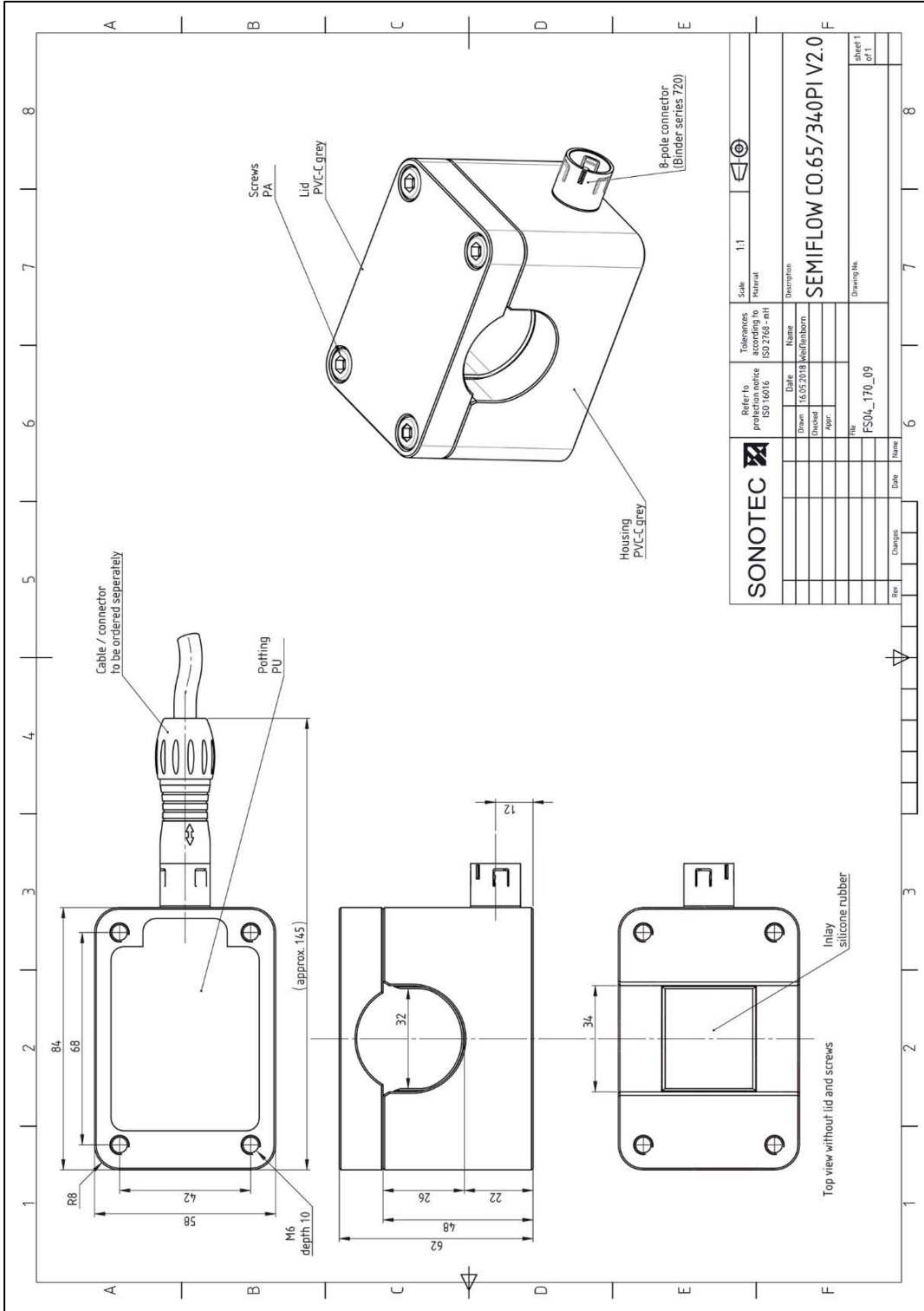

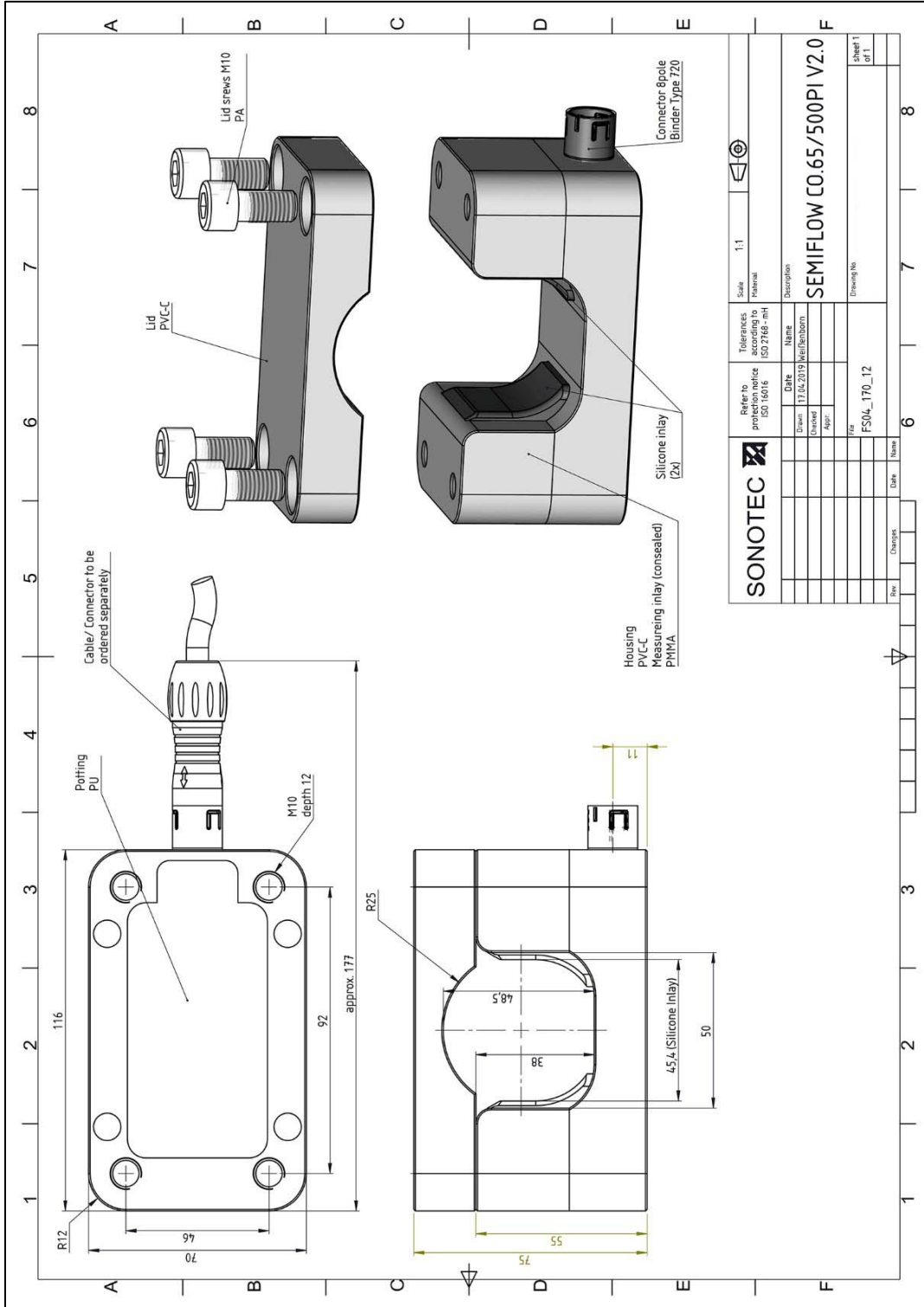

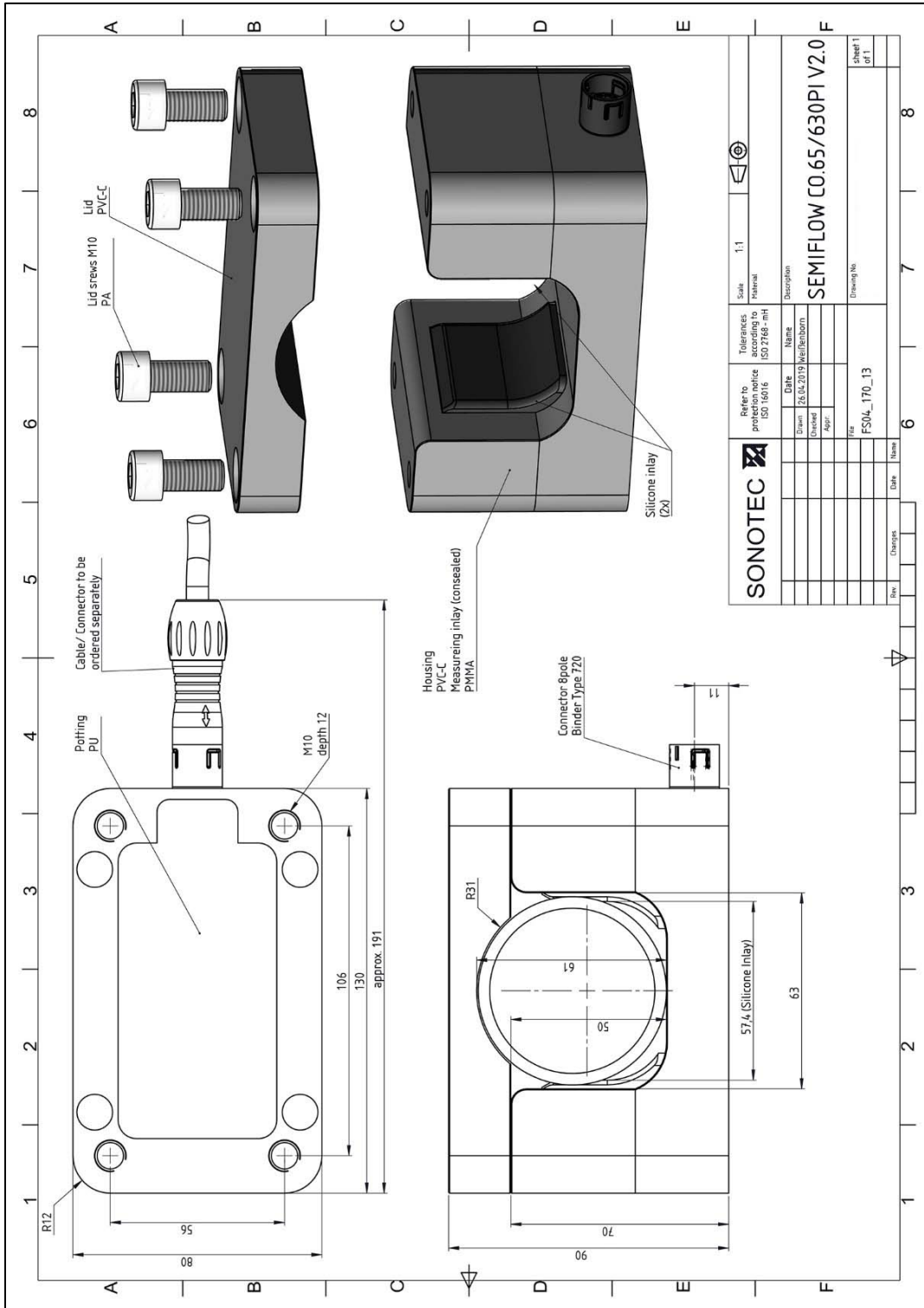

Modbus® is a registered trademark of Schneider Electric and is licensed by the Modbus Organization, Inc.
 Drawings are not to scale. Dimensions in mm, unless otherwise specified. Information is subject to change without notice.

MANUFACTURER
 SONOTEC GmbH
 Nauendorfer Str. 2
 06112 Halle (Saale)
 Germany

Tel.: +49 (0)345 / 133 17- 0
 sales_eu@sonotec.de
 www.sonotec.eu

CONTACT USA
 SONOTEC US Inc.
 190 Blydenburgh Rd.
 Suite 8, 2nd Floor
 Islandia, New York 11749, USA

Phone: +1 631 / 415 4758
 sales@sonotecusa.com
 www.sonotecusa.com