

The air bubble detector **SONOCHECK ABD07/xx-1** is used to detect air or gas bubbles in flexible plastic tubes and is intended to prevent air infusions. The sensor has no contact with the liquid and is suitable for applications particularly in medical devices. Designed as a component for fixed installation in machines and equipment it can be mechanically and electrically integrated.

The sensor sensitivity can be adapted to the requirements of individual operating conditions on request.

## Technical data

SONOCHECK type ABD07/xx-1 Air Bubble Detector		
<b>Measuring method</b>	Ultrasound	
<b>Bubble sensitivity</b>	Depends on sensor version and tube diameter, adjustment of the bubble sensitivity on request	
<b>Measuring cycle</b>	200 $\mu$ s	
<b>Response time, Holding time</b>	Minimum < 1 ms, typical 2 ms On request: Delays or holding times for bubble events	
<b>Operating temperature</b>	+5 °C to +60 °C	
<b>Materials</b>	Transducer and electronics potted in plastic housing	
<b>Version/designs</b>	The sensor version depends on the tube diameter, the hardness of the tube and its wall thickness.	
<b>Requirements for tube</b>	<b>Parameter</b>	<b>Property</b>
	Outer diameter	3.2 to 9.6 mm, according to specification of the sensor
	Wall thickness	Optimum: 10 to 20 % of outer diameter
	Material	Plastic, e.g. PVC, PE, silicone, PUR Other materials on request or after test only
	Special Features	Tube must be smooth on outside, no fabric tube
	Elasticity	Tube must be able to adjust flexibly
	Tube is inserted into sensor in dry condition	
<b>Liquid requirements</b>	Water, blood, solutions or other low-viscosity liquids containing no or few solids	

<b>Mounting</b>	Via 2 recessed holes on rear side of sensor (see technical drawings); self-tapping screws for plastics, Ø 3 mm, screw-in depth: min. 4 mm, max. 6 mm		
	Plane mounting with complete surface required; Maximum torque: 0.6 Nm		
<b>Protection</b>	IP67		
<b>Cleaning</b>	<p>⚠ <b>Caution!</b></p> <p>Incorrect cleaning of the ABD07/xx-1 sensor and its components can present a hazard for the user. Cleaning is prohibited</p> <ul style="list-style-type: none"> <li>• in a steam sterilizer or with hot steam in general</li> <li>• with white spirit or acetone</li> <li>• by immersion in solvents or other liquids</li> </ul>		
<b>Operating voltage</b>	+5 ± 0.2 VDC		
<b>Current consumption</b>	≤ 30 mA		
<b>Connecting cable</b>	4 x single wires; firmly connected to the sensor; length: 50 ± 2 cm		
<b>Inputs and outputs</b>	<b>Color</b>	<b>Connection</b>	
	Red	Operating voltage	
	Yellow	ABD-IN, Bubble test input (5 V logic, TTL) Test of the sensor by simulating a bubble, L-active	
	White	ABD-OUT, Output (5 V logic, TTL)	
	Blue	Ground (GND)	
<b>ABD-OUT</b>	<p>⚠ <b>Attention:</b></p> <p>The sensor output is not short circuit proof, any overvoltage or overcurrent exceeding the maximum rating will permanently damage the sensor (max. voltage: 5.5 V; max output current 8 mA).</p>		
	<b>Default configuration</b>		
	<b>Condition</b>	<b>Signal at output ABD-OUT (H/L: TTL output)</b>	<b>LED</b>
	Air/Bubble	H	red
	Liquid	L	green
	Internal error (self-test)	H	---
	<b>Alternative configurations</b>		
	Switching output: the specification of the output levels can be adjusted		
	<ul style="list-style-type: none"> <li>• Serial interface</li> <li>• Pulse-width-modulation, width of pulse depends on bubble size</li> </ul>		

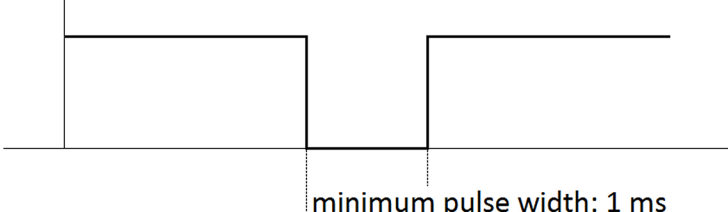
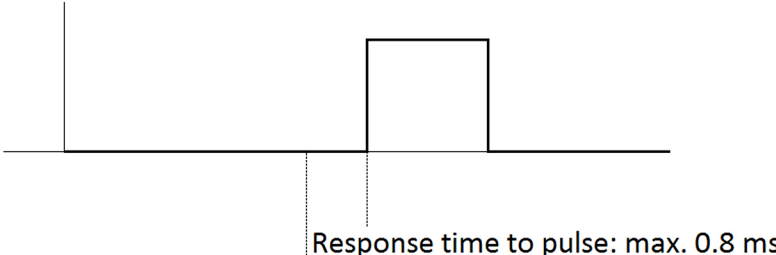
<b>ABD-IN, Bubble test input</b>	<p>The bubble test input triggers the sensor to simulate bubbles.</p> <p>Please note: At high flow rates (flow speed &gt; 500 mm/s) the sensor might miss real bubbles during this period!</p> <p>In default configuration the signal is low active. The minimum pulse width is 1 ms. During this period the transmitted ultrasonic pulses are decreased. This reduced signal is processed by the sensor in the same way as a real bubble would be processed. That means, the sensor does not differentiate between a real bubble and the test, the output ABD-OUT is set to 'Air/Bubble' (H), and the LED is set to red.</p> <p>To ensure, that the sensor is working properly, the machine which controls the sensor should trigger this bubble test periodically. The machine should check, whether the sensor output is set to 'Air/Bubble' as reaction on the input pulse.</p> <p>Input ABD-IN:</p>  <p>Output ABD-OUT:</p>  <p>Timing diagram of bubble test</p>
<b>Directives/standards</b>	<p>The sensors were developed to be tested with respect to the following standards:</p> <ul style="list-style-type: none"> <li>• Safety Requirements: IEC 60601-1:2005 (3rd edition)</li> <li>• EMC: EN 60601-1-2:2007 (3rd edition)</li> <li>• Acoustic Output (Ultrasonic): IEC 61157:2007</li> </ul>
<b>Scope of delivery</b>	<ul style="list-style-type: none"> <li>• SONOCHECK air bubble detector, type ABD07/xx-1</li> <li>• Technical data sheet</li> </ul>
<b>Accessories/options</b>	<p>ABD Monitor for configuration and diagnostics, consisting of:</p> <ul style="list-style-type: none"> <li>• USB data converter (Type 007)</li> <li>• USB cable, type A-B, length 1.5 m</li> <li>• CD with ABD Monitor software</li> </ul>

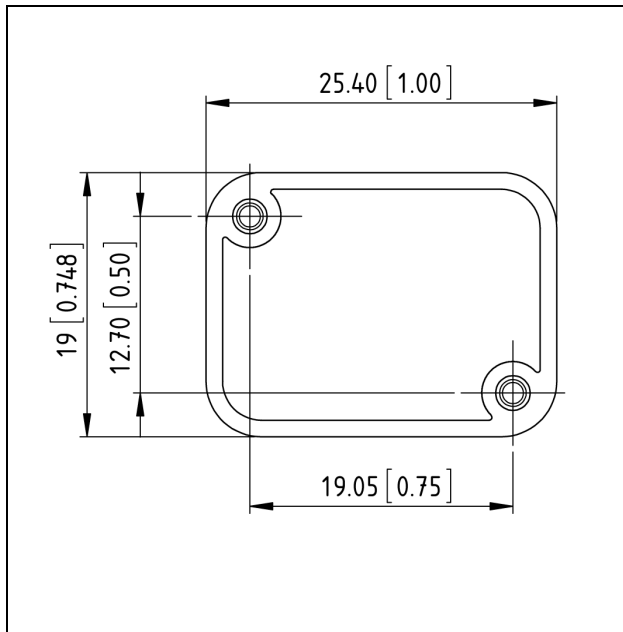
Technical drawings

Sensor dimensions in mm [inch]

(The drawings are not to scale)

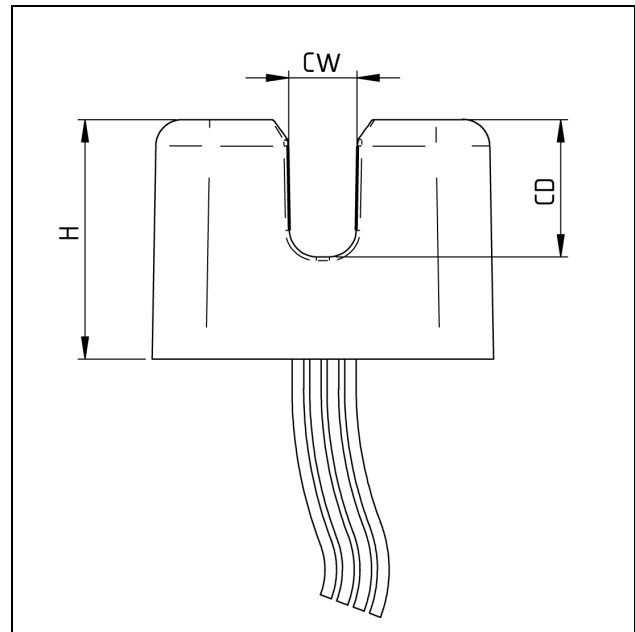

Channel dimensions and sensor height

Information for ordering

Specification	ABD07/25-1		ABD07/30-1		ABD07/50-1		ABD07/80-1	
	[mm]	[inch]	[mm]	[inch]	[mm]	[inch]	[mm]	[inch]
<b>Outer diameter of tube</b>	3.2	1/8	4.0	0.157	6.4	1/4	9.6	3/8
<b>CW: Channel width</b>	2.5	0.1	3.2	0.125	5.1	0.2	7.9	0.31
<b>CD: Channel depth</b>	8.25	0.325	8.9	0.35	10.2	0.4	13.3	0.524
<b>H: Sensor height</b>	15.75	0.62	16.5	0.65	17.8	0.7	21	0.827
<b>Order number</b>	200 02 0087		200 02 0088		200 02 0089		200 02 0090	

Drawings are not to scale. Information is subject to change without notice!

**HEADQUARTERS GERMANY**

SONOTEC GmbH  
 Nauendorfer Str. 2  
 06112 Halle (Saale)  
 Germany

Tel.: +49 (0)345 / 133 17- 0  
 sales\_eu@sonotec.de  
 www.sonotec.eu

**AMERICAS**

SONOTEC US Inc.  
 190 Blydenburgh Rd  
 Suite 8, 2<sup>nd</sup> Floor  
 Islandia, New York 11749, USA

Phone: +1 631 / 415 4758  
 sales@sonotecusa.com  
 www.sonotecusa.com